



## **Printondemand-Worldwide.com**

### **Distributor Relations Overview**

#### *Overview*

For publishers wishing to work with PODW through their distributor PODW can integrate directly with any distributor. PODW already works with a number of UK Book Distributors either as a short run printer supplying stock into the distributor or taking feeds direct from them and shipping direct to the end customer with invoice paperwork.

PODW provides a secure 'virtual library' which is an electronic document/publications warehouse facility (BookVault) that holds live publications in a pdf print ready format ready for print. This allows us to respond quickly to publisher or distributor order requirements and enables the publisher to update/change metadata and title files document easily and efficiently.

Our BookVault software is an automated online ordering system and allows publishers to place orders directly with us using a password protected web interface, or it can be configured to receive orders in XML format direct from a publisher's e commerce enabled website or internal order processing system (e.g. SAP), or configured to take an order stream direct from a distributor.

This functionality gives publisher's the option of placing orders direct with PODW (e.g. office copies, review copies) themselves via a protected web interface whilst still working with their distributor to send orders direct to PODW directly into the BookVault order processing software.

We require publisher authorisation to take order streams direct from their distributor. We need this authorisation because we will bill the publisher for the book manufacture and freight unless otherwise directed (freight billing is dependent on how the distributor selects to work with us (see below)).

Three order fulfilment options are available to the publisher/distributor as follows:

- (a) Order stream received directly from the distributor direct to PODW BookVault software. Printed books can be consolidated on to a pallet for weekly/daily delivery back to the distributor. Distributor has the option of collection direct from PODW. With large

volumes PODW can use the distributor's freight charging account if required. If PODW deliver the distributor is charged a pallet charge. This is an option for distributors who prefer to consolidate POD orders with non-POD stock items, e.g. a bookstore may not accept split deliveries or stock may be destined for a consolidated overseas delivery.

- (b) Order stream received directly from the Distributor direct to PODW BookVault software. A spool file or pdf file is also sent with the order stream containing invoice/customer documentation. PODW processes both the order file and customer paperwork file and ships the order direct to the end customer with an invoice, pick/pack paperwork. PODW can work with the distributor to customise despatch notes (e.g. distributor or publisher logo and text).
- (c) Order stream received directly from the Distributor direct to PODW BookVault software. PODW processes order and ships the order direct to the end customer. All customer invoicing is handled direct by the distributor and only the print item and a despatch note is sent to the end customer.

PODW can deliver:

- Back to distributor
- Direct to end customer (option of paperwork with the delivery)
- Freight forwarder

## ***Overview BookVault Integration Software***

PODW can receive orders directly from a publisher's distributor direct to the print floor via our automated order fulfilment software system known as BookVault. BookVault contains details of every order placed into a publisher's individual account and the status of each order. Every hour our automated production console communicates with the BookVault server to retrieve new orders. After checking for errors (missing files or titles on hold status) the order is acknowledged. The status of the order is fed to the distributor via the return feed, as follows:

- (a) Status Acknowledged
- (b) Status Printed
- (c) Status Despatched
- (d) Status Invoiced (if relevant)

In order to integrate with your distributor they must be capable of producing a file containing order details. There are many ways to export data, e.g. Edifact, X.12, Ascii flat file and XML. XML is becoming an increasingly popular way to export data. PODW can provide your distributor's IT department with an XML integration document if this is the preferred integration method. PODW can also work with your distributor to accept other order file types containing meaningful data.

Depending on the complexity of the implementation and data file to be transferred full data testing can take as little as two weeks.

Detailed system implementation guidelines are available on request. Bespoke implementations are also handled by our IT team.

### Data Recovery Capability

All data files are held on our internal fire-proof server and backed up daily. Spool files are also held and the data is also held securely offsite at another fire-proof location. This means in the case of any business interruption data and files can be recovered easily.

## Overview of Print On Demand (POD) Order Flow

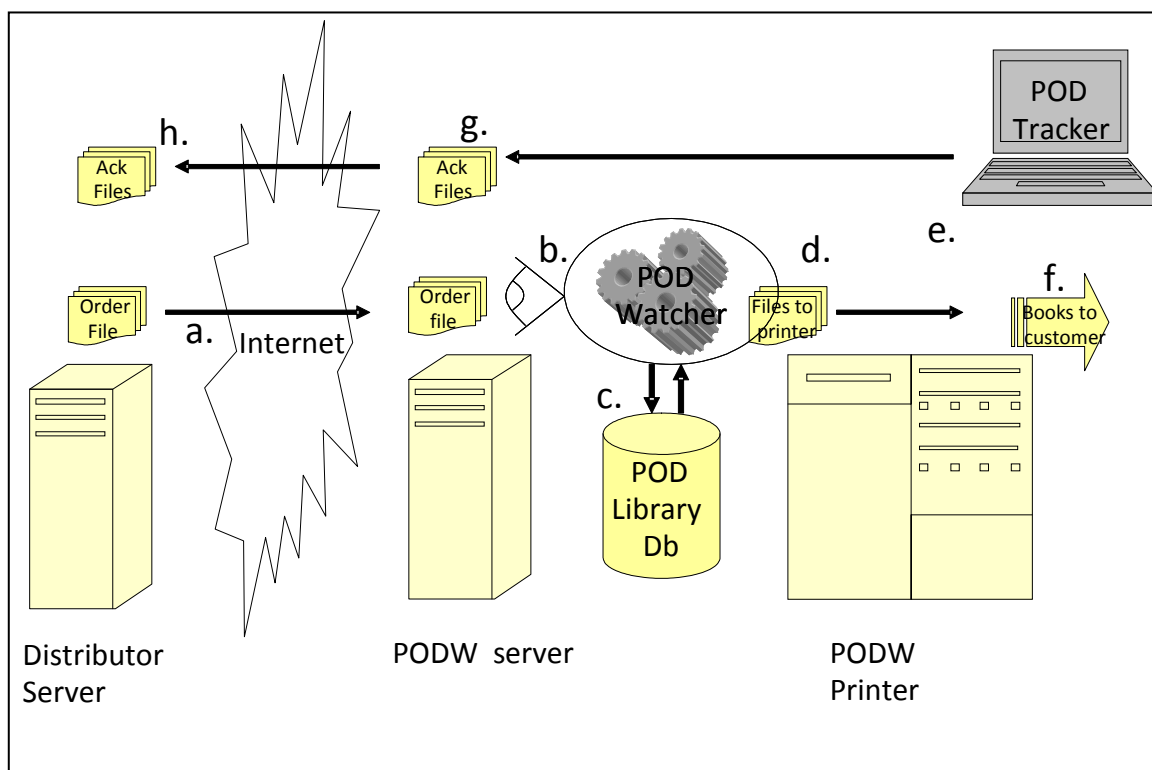

- a. Distributor feed orders from order management system onto the PODW Server
- b. POD Watcher sees new order arrived and starts processing
- c. POD Watcher then checks with POD Library database to identify what files to send to the printer for each book/item in the order
- d. POD Watcher sends appropriate files to printer
- e. Books/print items then despatched to clients
- f. POD Tracker creates Acknowledgement files on PODW server
- g. Acknowledgement files (Order Acknowledgement and Dispatch acknowledgement) from PODW server to Distributor server.

## Components of Copytech Print On Demand (POD) system

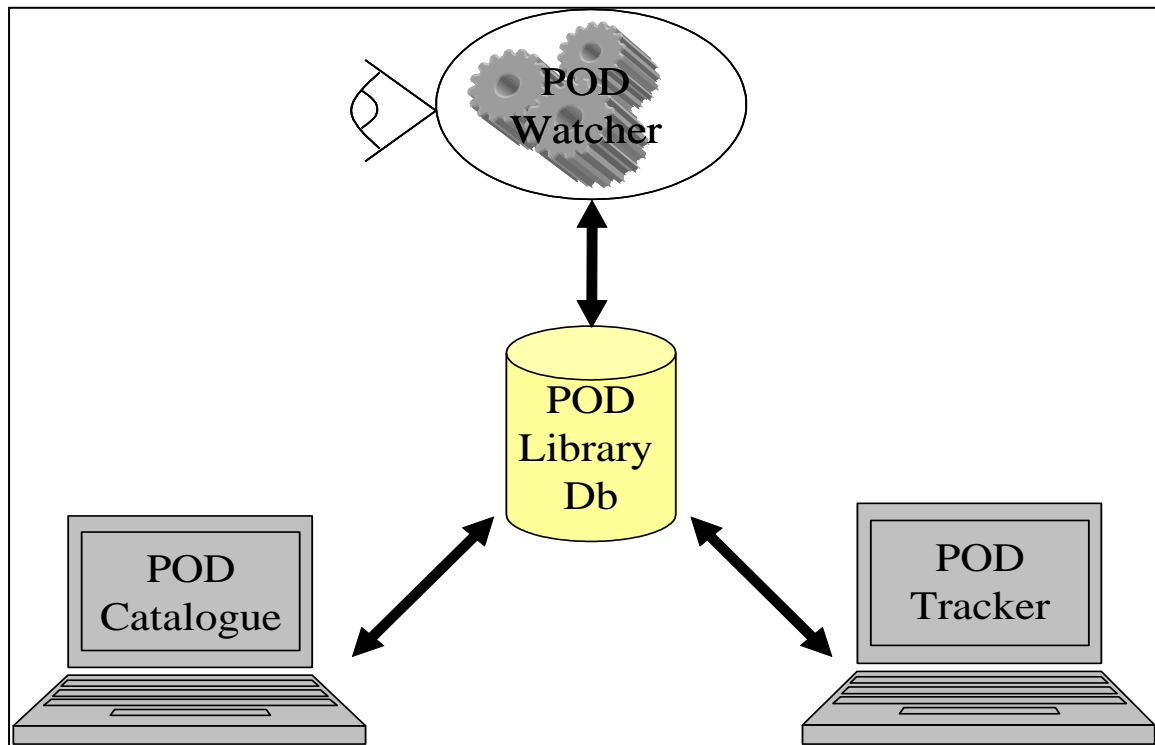

**POD Watcher** – waits for Order files, then checks with POD Library DB to identify which files need to be sent to print, then queues the files for printing.

**POD Tracker** – is used by the order control person to ensure that what has been ordered has been printed and what has been printed has been dispatched. As part of this process POD Tracker creates the Order Acknowledgement and Dispatch Acknowledgement files that distributor picks up from the server

**POD Catalogue** – is the application used to maintain the POD Library Database to show which files need to be printed to produce each book/item.